

AA6D45HM

STANDARD MATERIALS AND CONSTRUCTION

FRAME: .081" thk. (nominal) extruded aluminum, 6063-T52/T6 alloy.
Channel type.

BLADE: .081" thk. (nominal) extruded aluminum 6063-T52/T6 alloy.
Blades are approximately 4½" on centers.

LOUVER FACE: Full width sill with drain head and drain blades contained within drain jambs.

SHAFT: .50" dia aluminum "Pin-Lock" rod.

BEARINGS: Celcon bearing material so that there will be no metal to metal friction.

LINKAGE: Extruded aluminum, concealed in the channel out of the airstream. The pivots, which rotate in Celcon bearings, are .50" dia. plated and machined steel. The pivot is locked to the 5/16" dia. aluminum linkage rod by a ¼ - 20 set screw with epoxy locking patch.

SEALS: Extruded silicone rubber seals at blade edge.
Polyurethane at jambs.

SCREEN: (When indicated, in a removable frame)
½" flattened aluminum, .051" thk.,

- or- ½" sq. mesh intermediate double crimped aluminum wire, .063" dia.,
- or- 19/16" aluminum mesh insect screen, .011" dia.

FINISH: Mill.

ACTUATOR: 120 VAC spring return normally closed.
133 in.-lbs. torque.

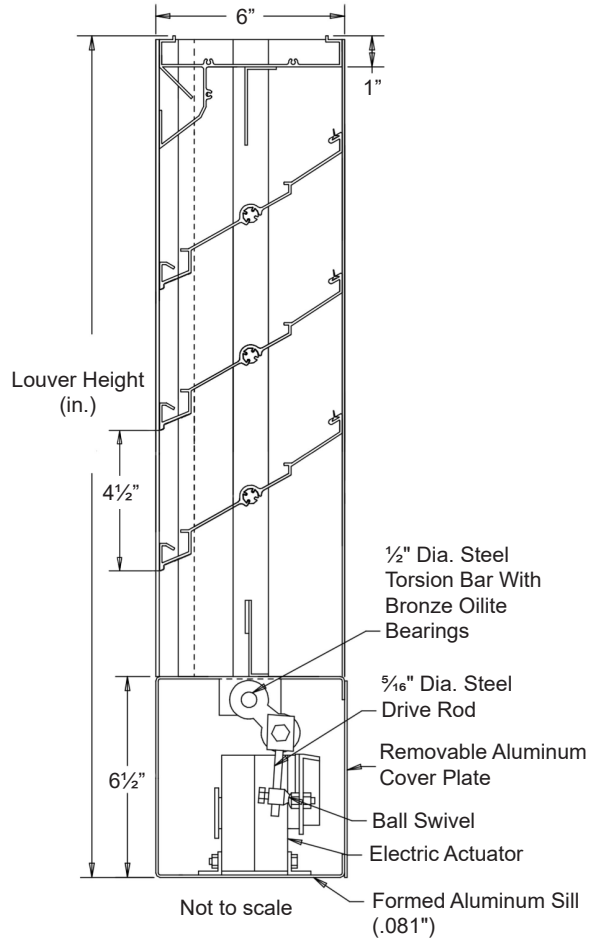

OPTIONS

Finishes - Enamels, Epoxies, etc.
Other screens also available.

NOTES

1. Nominal deductions will be made to the opening size given.
2. Approximate shipping weight is 5.6 lbs./sq.ft.

LOUVER SIZES

Min Panel	Max Single Panel
12"W x 19"H	48"W x 96"H

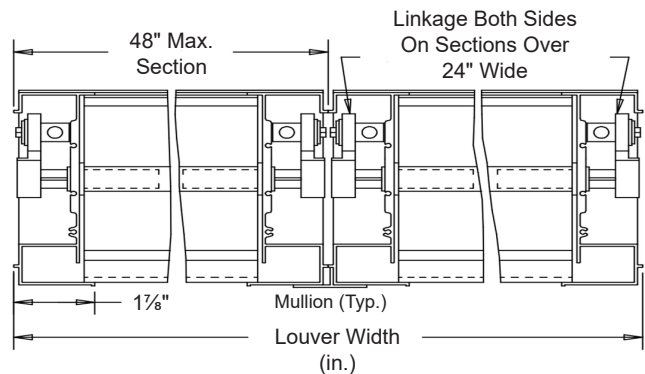

In the interest of product development, Airline Louvers reserves the right to make changes without notice.

										
Item #	Qty	Width	Height	Width	Height	Mullion	Type	Location		
		Opening Size		Louver Size			Screens			Union Made
Arch. / Eng. :						EDR:	ECN:		Job:	
Contractor:										
Project:						Date:	DWN:	DWG:		

1020 Prince Frederick Blvd. Suite 305 • Prince Frederick, MD 20687 • Phone: (570) 420-7079 • Fax: (570) 420-7078